

Reduction of life cycle impacts of oil shale electricity caused by the shift to fluidized bed combustion technology

Siret Talve*, Evelin Põld

Rank OÜ, Leina 14A, 11612 Tallinn, Estonia

Received 19 February 2022, accepted 14 October 2022, available online 10 December 2022

Abstract. *In 2004–2005, the pulverized firing technology that had been used for decades was replaced with fluidized bed combustion in some boilers of two major power plants located in North-East Estonia. The objective of the current study was to identify the impact of this technology switch on the efficiency, resource use and environmental performance of oil shale electricity generation. The Life Cycle Assessment (LCA) methodology according to the International Organization for Standardization (ISO) 14040 series and the International Environmental Product Declaration (EPD) System standards was applied to analyzing the effects of the mentioned technology switch. In this study, the functional unit of the product system of oil shale electricity is 1 kWh of oil shale electricity transmitted to the Estonian customer. The specific oil shale electricity inventory data that can be used in life cycle assessments of other products are presented. The comparison of the life cycle environmental impact of oil shale electricity before and after changing the combustion technology is provided. Climate change caused by greenhouse gas emissions is the key impact to be tackled. The gain in electricity generation efficiency due to the change of the combustion technology had a remarkable positive impact on greenhouse and acidifying gas reduction. Also, the impact on creating ground-level ozone and eutrophication diminished. Reduction of ozone depleting gases, however, was minimal. The critical review of this LCA has been carried out by an independent expert.*

Keywords: *Estonian oil shale, oil shale thermal power plant, oil shale electricity inventory data, life cycle assessment.*

1. Introduction

Considering unstable prices of traditional fossil energy carriers such as oil and gas, unconventional fossil sources are screened for energy production. The technology and challenges of alternative fossil fuels like shale oil and gas

* Corresponding author: e-mail siret.talve@gmail.com

have been well described by Sohrab Zendehboudi and Bahadori [1]. Estonia is unique due to its energy supply that has been based on such an unconventional fossil fuel like oil shale since the 1950s. Local high quality oil shale (kukersite) was used at a small scale already before the Second World War to produce shale oil, but after the war when the Soviet Union occupied Estonia, large-scale oil shale industry, including oil shale mining, energy generation (heat and electricity) and later also shale oil production, was established in North-East Estonia. Estonia's oil shale industry is currently the most developed in the world, especially in terms of power industry. The share of oil shale in its 2008 electricity generation profile was 90%. Due to the remarkable growth of the use of renewable sources for electricity generation (17% in 2018) and the opening of the electricity market in 2013, the oil shale share in the country's energy profile has reduced by about 35%, being 54% in 2020, according to the Oil Shale Competence Center [2].

Oil shale in Estonia lies in underground beds where its layers alternate with intermediate layers containing limestone, mainly carbonates. In the oil shale layers, the organic matter is tightly intertwined with sandy-clay minerals. Oil shale is mined both in open casts and underground mines. Oil shale organic matter contains, in addition to hydrogen, a large amount of oxygen and a moderate quantity of nitrogen. The characteristics of oil shale used at Estonian power plants are as follows: moisture 11–13%, ash 45–47%, mineral carbon dioxide 16–19%, sulfur 1.5–1.7% and the lower heating value 8.3–8.7 MJ/kg. Oil shale as a hydrogen-rich fuel is characterized by a very high content of volatile matter. The content of volatiles in organic matter is 85–90%. The main air pollutants formed during the combustion of oil shale are nitrogen oxides (NO_x), SO_2 and solid particles. Ots [3] has established that the major greenhouse gas emitted is carbon dioxide. The environmental problems related to Estonian oil shale industry have been thoroughly studied by Raukas and Punning [4].

Oil shale belongs to the class of sapropel fuels. It is widely distributed around the world; more than 600 deposits are known to exist, with resources of over 600 Gt (in oil equivalent). Today, considerable quantities of oil shale are mined in Estonia, Russia, China, but also in Brazil, Australia and Germany. In China oil shale is, like in Estonia, used for both shale oil production and electricity generation and scientists make continuous efforts to develop comprehensive utilization technology [5].

The biggest oil shale-based power plants in the world – Balti Thermal Power Plant (Balti TPP, installed capacity 322 MW, launched in 1959) and Eesti Power Plant (Eesti PP, 1,355 MW, launched in 1969) – are situated in North-East Estonia, close to the Estonian-Russian border. To increase energy generation efficiency and meet requirements of the current climate policy there appeared a need to improve the technology that had been used for decades. The reconstruction of the plants consisted in the modernization of the burning technology of two blocks, both containing two boilers – conventional burning

(pulverized firing) was replaced with fluidized bed combustion in 2004–2005. The preliminary gains in energy generation efficiency and improving the environmental performance due to this change have been studied in Estonia by Hotta et al. [6], and also in China where such oil shale fired boiler was put into commercial operation already in 1996 [7, 8]. Life cycle assessment (LCA) has proved to be an appropriate methodological approach for the comparison of technologies and registration of achieved effects of technological improvements. The International Environmental Product Declaration (EPD)[®] System aims at standardization of the methodological approach and has developed Product Category Rules that define guidelines for the LCA of the energy production system [9].

The LCA approach has been previously used to study the operation of a small-scale oil shale thermal power plant by Talve and Riipulk [10], and to draw conclusions by the same authors [11] and Mangmeechai et al. [12] for improving the water management of oil shale industry. In addition, the environmental performance of possible future Estonian electricity supply scenarios has been assessed by Koskela et al. [13] using the LCA method. However, specific Life Cycle Inventory data about large-scale oil shale electricity production have not been published before.

The full oil shale electricity LCA was carried out in 2004–2005 and 2008, respectively before and after the major reconstruction of some boilers of the two biggest Estonian oil shale power plants. Specific data for a full year was collected on most of the unit processes of the oil shale electricity product system taking place in Estonia, which included two underground mines, an oil shale open cast, oil shale railway, two thermal power plants, and a number of auxiliary material producers like special metalwork companies and an explosives manufacturer. Therefore, the data quality was the highest possible. The compiled model was checked by the companies involved in the life cycle of oil shale electricity and critically reviewed by an internationally recognized LCA expert.

2. Data and methods

The life cycle assessment of oil shale electricity was carried out according to the International Organization for Standardization (ISO) 14040 series standards [14]. Specific product category rules developed by the International EPD[®] System for electricity generation and distribution were also followed [15].

2.1. Functional unit and system boundaries

Functional unit represents the quantified performance of a product system under investigation. It is a reference unit to which the system's inputs and outputs are related. The functional unit of the product system of oil shale

electricity is 1 kWh of oil shale electricity transmitted to the Estonian customer.

The inputs and outputs were identified and studied for all the unit processes of the oil shale electricity life cycle. The investigated product system is shown in Figure 1. Oil shale production involves oil shale mining in two underground mines and one open cast with some preliminary treatment to achieve the quality

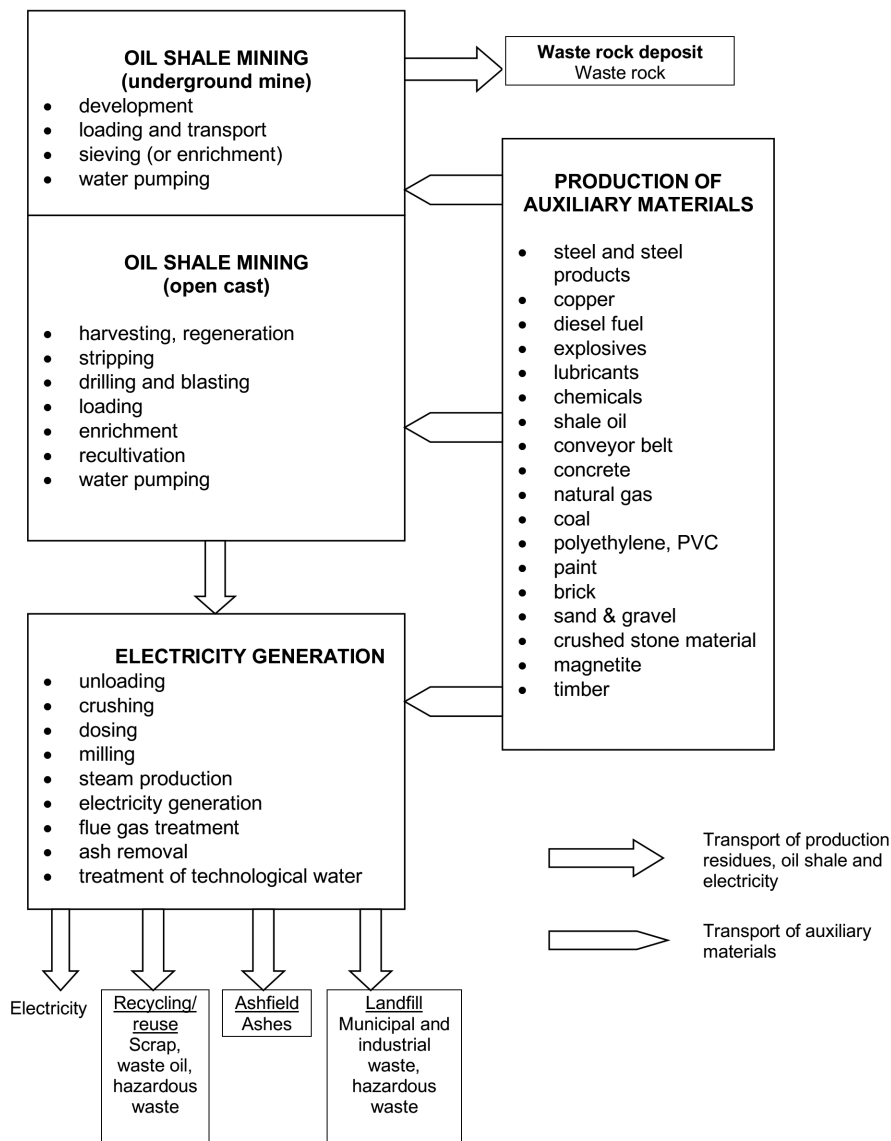

Fig. 1. System boundaries for the product system of oil shale electricity.

necessary for power plants. During the electricity generation phase, oil shale is burned and the generated steam is converted into electricity. This phase also includes the delivery of electricity to the electric grid with transmission losses considered. Auxiliary material production covers the manufacture of auxiliary materials necessary in mines and power plants. Transportation involves the conveyance of oil shale, auxiliary materials and production residues. The information concerning transportation (e.g., distances, modes of conveyance) is given in the respective profiles.

The following processes were excluded from the system boundaries:

- end use of electricity;
- construction and dismantling of oil shale extraction facilities;
- maintenance processes of the distribution network;
- building of infrastructure;
- production of manufacturing equipment.

For some unimportant auxiliary materials (e.g., NaCl, Na₃PO₄) the transportation data were not available and therefore the information on these materials conveyance was excluded from the study.

2.2. Allocation

Most industrial processes yield more than one product, and they recycle intermediate or discarded products as raw materials. Therefore, the materials and energy flows as well as associated environmental releases must be partitioned between the different products. Allocation is a procedure which aims at distributing the environmental burdens between the products in a life cycle. In the current study, allocation was avoided in case of oil shale mining and electricity generation at Eesti PP. Both power plants, Balti TPP and Eesti PP, co-produce heat and electricity. When Eesti PP consumes part of the generated heat for self-use purposes, then the heat generated by Balti TPP is used by the heating system and enterprises of Narva city. Therefore, allocation had to be applied to the inputs and outputs associated with the unit processes included in Balti TPP. The allocation principle chosen for Balti TPP followed the Alternative Generation Method, which describes this principle in case of combined heat and power generation [15].

Narva Oil Factory generates one main product, shale oil, and two by-products – phenol water and semi-coke gas. Most of the produced shale oil is consumed mainly as a raw material in the chemical industry and as a fuel. Eesti and Balti power plants use shale oil to heat up the boilers. The above-mentioned by-products of the Oil Factory are used only at Eesti PP as supplementary fuels. Therefore, allocation in terms of the Factory's three products had to be conducted as well. The allocation principle for shale oil, phenol water and semi-coke gas was based on their energetic values (heating values).

2.3. Inventory analysis

To form a basis for data collection, preliminary technological schemes (process flow diagrams) of all the open casts, underground mines and power plants belonging to the product system of oil shale electricity were composed. Data on oil shale mining and electricity generation were gathered from the administrations of all the mines, open casts and power plants located in North-East Estonia. In addition, data concerning the production and transportation of some auxiliary materials (e.g., chemicals) were acquired from databases, such as KCL EcoData, LIPASTO (Technical Research Centre of Finland, VTT), IISI (International Iron and Steel Institute) and Ecoinvent (Swiss Centre for Life Cycle Inventories). Based on technological schemes, the process flow diagrams were elaborated by KCL-ECO software and the gathered data were inserted in those schemes and further interpreted.

All the mines, open casts and power plants in North-East Estonia were modelled and data were collected about each unit process. The flow chart model of Aidu open cast is depicted in Figure 2. The main processes of an underground mine are displayed in Figure 3. Figure 4 illustrates power generation processes at Estonia's biggest oil shale power plant, Eesti PP.

2.4. Life cycle impact assessment

Life cycle impact assessment (LCIA) is the third phase of LCA, during which the values of environmental interventions identified and quantified in the inventory analysis are interpreted based on their potential contribution to environmental impact. The pollutant emissions were analyzed following the rules set in Annex B (Conversion and Characterization factors) of the General Programme Instructions for the International EPD System for environmental product declarations [16]. The studied impact categories included:

- greenhouse gases (CO_2 , N_2O , CH_4 , HCFC, CH_2Cl_2);
- acidifying gases (SO_2 , NO_x , NH_3);
- ozone depleting gases (HCFC);
- gases creating ground-level ozone (acetone, aldehydes, aliphatic compounds, aromatic hydrocarbons, benzene, butanol, CH_4 , ethane, ethanol, formaldehyde, HC, NMVOC, SO_2 , NO_x , VOC, toluene, xylene);
- eutrophying substances (COD, N, N_2O , NH_3 , NH_4 , NO_x , NO_2 , NO_3 , P_{tot} , P_2O_5 , PO_4).

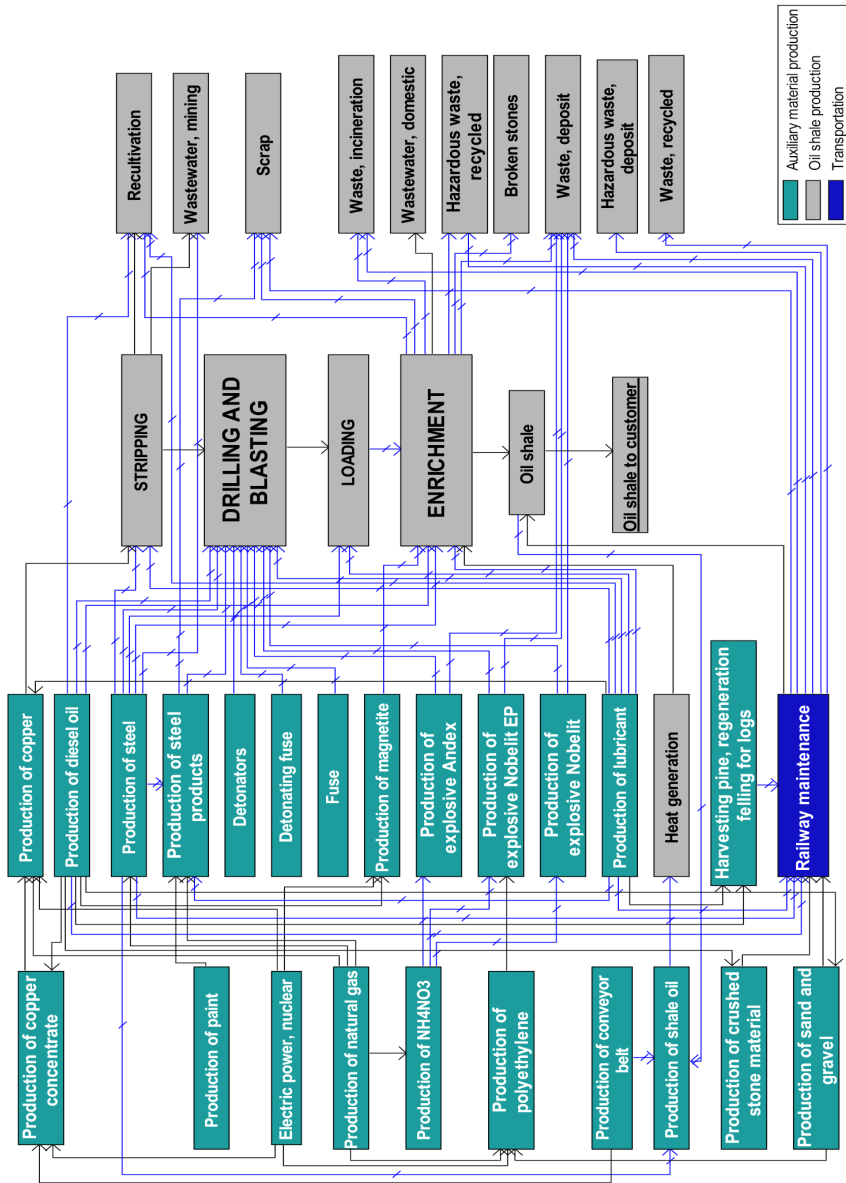

Fig. 2. Oil shale production processes in open cast (Aidu Open Cast).

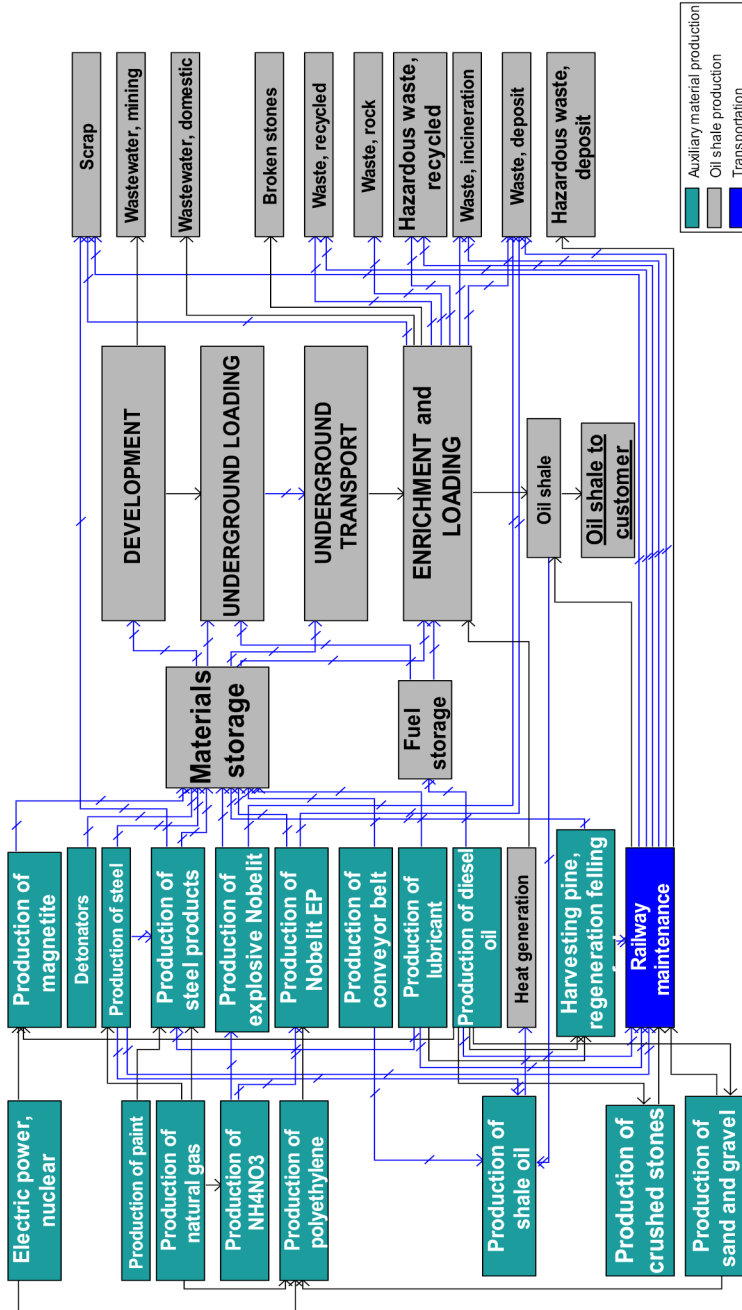

Fig. 3. Oil shale production processes in mine (Estonia Mine).

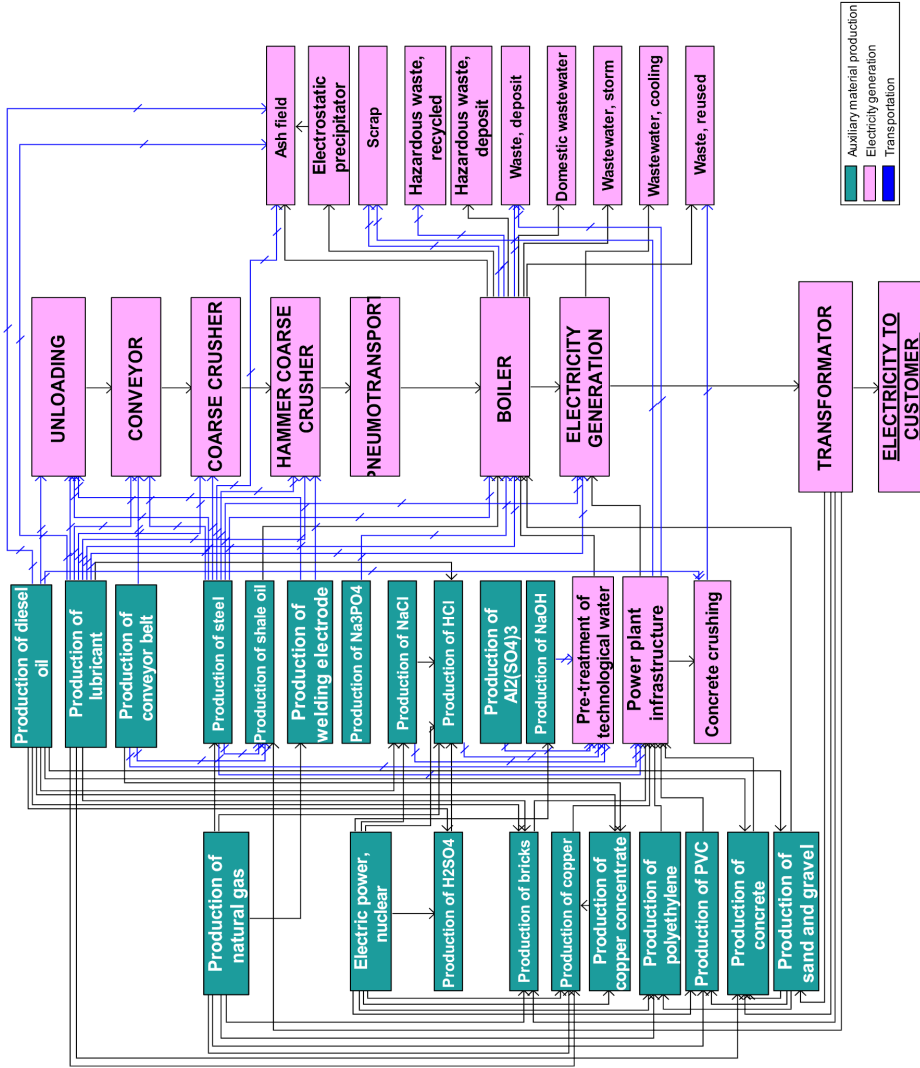

Fig. 4. Electricity generation processes (Eesti Power Plant).

3. Results and conclusions

3.1. Comparison of life cycle environmental impacts

Electricity generation at a power plant is the dominant source of environmental impact for most impact categories. Therefore, the combustion technology plays a key role in the environmental impact of the whole oil shale electricity generation life cycle. The global impacts in five selected impact categories were compared.

Climate change caused by greenhouse gas emissions is the key impact to be tackled. The current climate policy has a strong influence on the economic feasibility of oil shale energy generation. The air emissions from this kind of electricity generation are considerable due to the low calorific value of the fuel, but depend also on its type and composition, as well as combustion process parameters and overall power unit efficiency. The about 6% gain in electricity generation efficiency due to the change of combustion technology had a remarkable 27% positive impact on global warming potential caused by greenhouse gas emissions (see Fig. 5). The main contributor to climate change is the electricity generation phase of the life cycle, contributing to more than 98% of the climate change indicator (expressed as CO₂ eq). The CO₂ emissions account for 99.3% of the final indicator value whereas CH₄ and N₂O only play a minor role. The most notable impact was revealed by the reduction of the impact of acidifying gases (Fig. 6) and generation of ground-level ozone (Fig. 7). Also, in case of acidification, the main contributor is the electricity generation as about 97% of the acidifying emissions come from power plants. The main contributor is SO₂ (90%), followed by NO_x (9.1%); the importance of other emissions (HCl, HF, H₂S) is insignificant. The impact of eutrophication diminished about 59% (Fig. 8). In the oil shale electricity product system, the emission of NO_x in the electricity generation phase contributed to eutrophication most. The reduction of ozone depleting gases was minimal, 3% (Fig. 9).

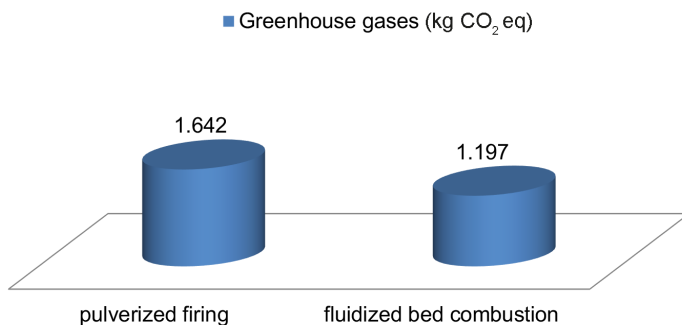

Fig. 5. Life cycle impact on greenhouse gas emissions (kg CO₂ eq) per functional unit (1 kWh of oil shale electricity at customer) before and after the change of the burning technology.

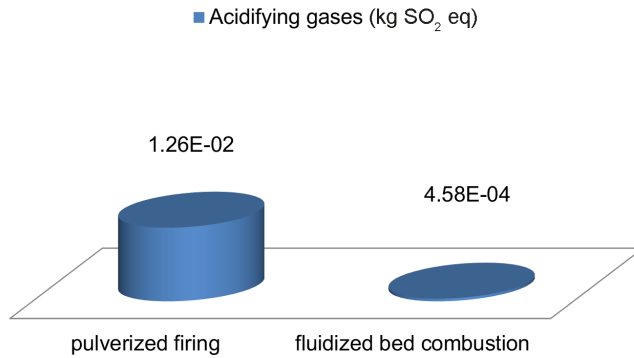

Fig. 6. Life cycle impact on acidifying gases (kg SO₂ eq) per functional unit (1 kWh of oil shale electricity at customer) before and after the change of the burning technology.

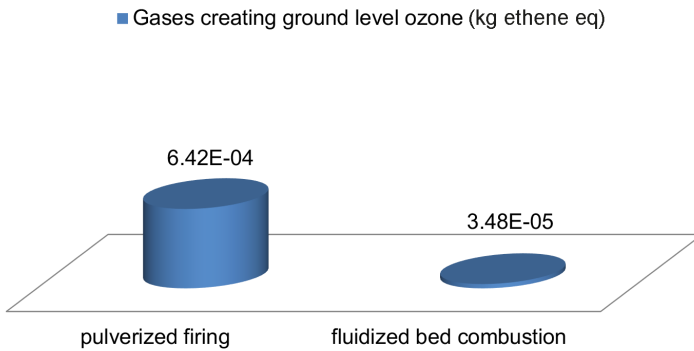

Fig. 7. Life cycle impact on gases creating ground-level ozone (kg ethene eq) per functional unit (1 kWh of oil shale electricity at customer) before and after the change of the burning technology.

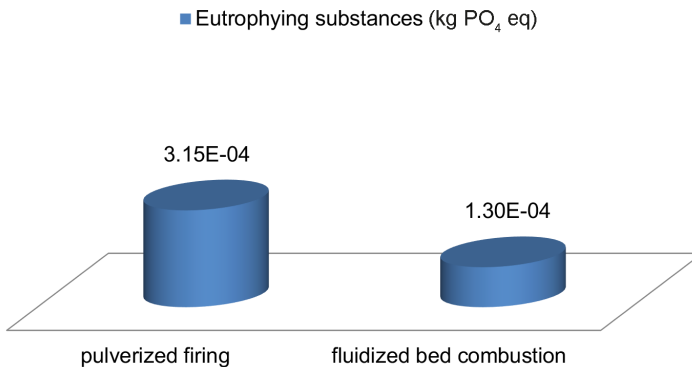

Fig. 8. Life cycle impact on eutrophying substances (kg PO₄ eq) per functional unit (1 kWh of oil shale electricity at customer) before and after the change of the burning technology.

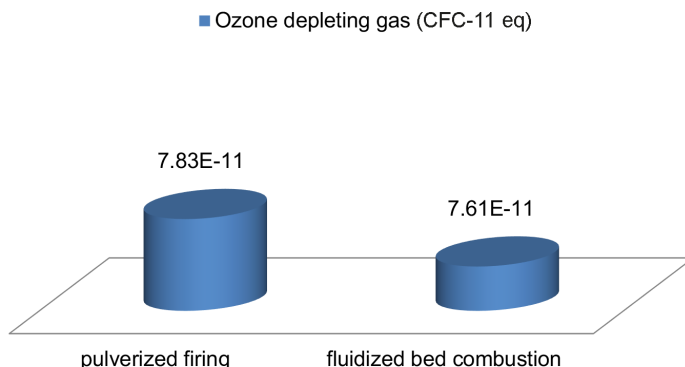

Fig. 9. Life cycle impact on ozone depleting gases (CFC-11 eq) per functional unit (1 kWh of oil shale electricity at customer) before and after the change of the burning technology.

3.2. Other impacts of oil shale electricity generation

Not all environmental impacts can be described by international models. Below considerable, mainly local, environmental impacts that do not depend directly on burning technology will be described.

A considerable impact of mining is caused by oil shale enrichment waste piled into artificial landforms that pollute both air and water. The main component of this enrichment waste is limestone that can be crushed and used, for example, in road construction. Some mines have such production units, but usually the demand is lower than the amount of waste generated.

On average 188 million m³ of water is pumped out of mines and open casts annually. As a result, a cone of depression is formed, the water level in local lakes falls, and people in the mining region have problems with getting water. The Cambrian-Vendian aquifer is the main source of central water supply; its level has lowered throughout the whole area. The pumped-out mine water does not meet the requirements applying to waters discharged into the environment. The chemical composition of local natural water bodies is slowly, but continuously changing due to the inflow of pumped-out mine water. After completing the mining activities, the underground mines will be filled with ground water, which causes big unpredictable changes in the water regime of the whole region.

The wash-out of elements from ash piles and their later infiltration into watercourses, groundwater and soil also needs proper investigation. The annual amount of precipitation in the area is 650 mm, natural evaporation being 400 mm. Therefore, on top of some of the dumping areas, large artificial ponds have been constructed to speed up the evaporation.

Due to the airborne ash, in Eastern Estonia and neighboring regions, the precipitation is alkaline. This is caused by the association of SO₂ and SO₃ with alkaline oxides of airborne ash taking place in high-temperature gas pipes of power plants, as well as by the high concentration of alkaline oxides in the atmosphere. Calcium-rich airborne dust has damaged the sphagnum carpet within 10–15 km around the emission sources. Part of the fine ash from precipitators is used in the building materials industry for production of cement and building blocks.

3.3. Results of life cycle inventory

As illustrated in the figures above, the environmental performance of oil shale electricity improved remarkably due to the new combustion technology. The results of the life cycle inventory give a comprehensive overview of the need for different resources for oil shale electricity production, as well as of the amounts of emissions and waste (respectively Tables 1, 2, 3) in case of fluidized bed combustion.

Table 1. Use of resources per 1 kWh of oil shale electricity (fluidized bed combustion technology)

ECOPROFILE – Resource use	Unit	per kWh net electricity	per kWh electricity at customer
Non-renewable material resources			
Aluminum	g	2.29E-02	2.59E-02
Calcite	g	1.44E-01	1.63E-01
Dolomite	g	4.22E-02	4.77E-02
Iron ore	g	2.3	2.6
Sand and gravel	g	8.24E-01	9.29E-01
Renewable material resource			
Wood	g	3.43E-01	3.87E-01
Non-renewable energy resources			
Coal	g	1.8	2.0
Natural gas	g	2.4	2.7
Crude oil	g	3.0	3.4
Oil shale rock	g	1868.4	2107.5

Table 1 (continued)

Renewable energy resources			
Biomass (incl. water)	g	4.61E-07	5.20E-07
Electricity consumed in the energy conversion plant			
Electricity self-use by CFB blocks	kWh	1.16E-01	1.31E-01
Water use			
Cooling river water for CFB blocks	g	112 525	126 923
Technological water for CFB blocks (surface water)	g	503.0	567.4
Mine water	g	24 002.9	27 076
Water for auxiliary materials production	g	437.3	493.2
Use of recycled material			
Ferrous scrap	g	9.14E-02	1.03E-01
Input of materials from technosphere			
	g	4.27E-01	4.82E-01

Table 2. Main pollutant emissions per 1 kWh of oil shale electricity (fluidized bed combustion technology)

ECOPROFILE – Pollutant emissions	Unit	per kWh net electricity	per kWh electricity at customer
Emissions mainly contributing to given impact categories			
Ammonia, air	g	1.56E-02	1.76E-02
Carbon dioxide, fossil	g	1051.3	1185.8
Chemical oxygen demand	g	2.21E-01	2.49E-01
Dinitrogen monoxide	g	3.11E-02	3.50E-02
Hydrocarbons	g	7.98E-03	9.00E-03
Hydrochlorofluorocarbons	g	2.04E-07	2.31E-07
Methane	g	2.12E-02	2.39E-02
Nitrogen, water	g	5.00E-02	5.64E-02

Table 2 (continued)

Nitrogen oxides	g	6.09E-01	6.87E-01
Non-methane volatile organic compounds	g	5.07E-03	5.72E-03
Phosphorus, water	g	2.16E-04	2.44E-04
Sulphur dioxide	g	1.02E-01	1.15E-01
Volatile organic compounds	g	2.83E-04	3.19E-04
Emissions of toxic and other substances to air and water			
Carbon dioxide, biological origin	g	2.28E-02	2.57E-02
Carbon monoxide	g	2.90E-01	3.27E-01
Heavy metals	g	7.40E-03	8.35E-03
Oil to water	g	3.70E-03	4.18E-03
Particulate matter	g	1.58E-01	1.78E-01
Radon-222	kBq	1.51E-02	1.70E-02

Table 3. Main wastes and recycled materials outputs per 1 kWh of oil shale electricity (fluidized bed combustion technology)

ECOPROFILE – wastes and materials subject to recycling	Unit	per kWh net electricity	per kWh electricity at customer
Fuel-related waste (core module)			
Ash from power generation to deposit	g	496.9	560.5
Hazardous waste – non-radioactive (core module)			
To landfill	g	5.43E-05	6.12E-05
To reuse	g	2.21E-03	2.49E-03
To recycling	g	11.3	12.7
Other waste (core module)			
To landfill	g	3.60E-01	4.06E-01
To reuse	g	54.7	61.7
To recycling	g	2.0	2.3

Table 3 (continued)

Solid wastes from upstream and downstream processes			
Ash from suppliers' processes	g	3.0	3.3
Hazardous waste	g	5.74E-02	6.47E-02
Enrichment waste, deposit (inert waste – rock)	g	412.5	465.2
Enrichment waste, reuse (inert waste – rock)	g	10.5	11.9
Waste, unspecified	g	3.4	3.9

4. Conclusions

The selection of burning technology plays a key role in the efficiency of electricity generation and is also crucial for determination of environmental performance. In case of generation of oil shale electricity, the switch in 2004–2005 from pulverized firing to fluidized bed combustion technology in boilers was successful and a remarkable reduction in the negative environmental impact was gained due to the increase of the energy generation efficiency. The efficiency of the previously used pulverized firing technology was about 30%, 25% of the primary energy reached consumers, considering the energy used for production of auxiliary materials, and losses. The technological shift improved the efficiency about 6%. All the other facilities of the power plants like flue gas purification and ash removal systems were not replaced. However, there have been successful efforts to reduce power transmission losses and currently the network loss is below 10%. Also experiments to use biomass up to 50% of total fuel consumption, along with oil shale in the power plant fluidized bed boilers proved successful, reducing fossil fuel-related emissions. On other boilers some new filters to reduce sulphur dioxide emissions have been installed. The main change in mining technology is related to applying new milling harvesters in the biggest open cast. This has increased the efficiency of mining operations, but with no remarkable impact on the environmental performance.

If compared to other fossil fuels, the oil shale electricity generation process yet remains polluting, as the process efficiency depends on the nature of fuel. Considering the current European Union's climate policy, the long-term economic feasibility of oil shale electricity generation is questionable. In 2019 four blocks of oil shale energy generation units, three at Balti Thermal Power Plant and one at Eesti Power Plant, with a combined capacity of 619 MW, were closed as their allowed working hours had passed. Further research to improve combustion efficiency, reduce greenhouse and acidifying gas

emissions and reuse wastes like rock from enrichment and ashes from power plant boilers is needed as, according to the current plans, the old plants will be still operational in the next decade.

A new 274 MW Auvere oil shale power plant, located close to Balti and Eesti power plants, was launched in 2015, but as its air emissions did not meet expected environmental parameters, the plant was fully commissioned just in 2018. It can cover about 25% of Estonia's electricity consumption, 2.2 TWh out of 8.0 TWh. Besides oil shale, also peat, shredded old tires and biomass can be used in this power plant. The dust emissions from Auvere power plant are considerably lower than those from the old plants.

However, in the longer term, the production of electricity from oil shale will not be economically viable due to the climate policy requirements. In the future, it is planned to focus mainly on shale oil production – the construction of a new modern oil factory is underway.

Acknowledgments

The Life Cycle Assessment data on pulverized firing technology was collected within the European Union LIFE-Environment demonstration project OSELCA (LIFE03 ENV/EE/000194) – Introduction and Implementation of Life Cycle Assessment Methodology in Estonia: The Effects of Oil Shale Electricity on the Environmental Performance of Products. The beneficiary of the project was Eesti Energia AS who is the key actor in oil shale-based power generation in Estonia. The partners were the Finnish Environment Institute (SYKE) and CyclePlan OÜ (currently Rank OÜ). Jyri Seppälä and Sirkka Koskela from SYKE provided methodological support with said LCA.

The LCA study of oil shale electricity produced by the fluidized bed combustion technology was funded by Eesti Energia AS. Håkan Stripplé and Tomas Rydberg from IVL Swedish Environmental Research Institute Ltd provided methodological support with this LCA. The critical review was carried out by Lars-Gunnar Lindfors from IVL.

The publication costs of this article were covered by the Estonian Academy of Sciences.

REFERENCES

1. Zendejboudi, S., Bahadori, A. *Shale Oil and Gas Handbook: Theory, Technologies, and Challenges*. Australia: Elsevier Inc., 2015. doi:<https://doi.org/10.1016/C2014-0-01653-X>
2. Oil Shale Competence Center. *Oil Shale Industry Yearbook 2020* (Oone, A., ed.). Kohtla-Järve: Tallinn University of Technology, Eesti Energia AS, Viru Keemia Grupp AS, Kiviõli Keemiatööstus OÜ, 2021 (in Estonian). <https://taltech.ee/polevkivi-kompetentsikeskus-aastaraamat>

3. Ots, A. *Oil Shale Fuel Combustion*. Tallinn: Tallinna Raamatutrükikoda, 2006.
4. Raukas, A., Punning, J.-M. Environmental problems in the Estonian oil shale industry. *Energy Environ. Sci.*, 2009, **2**(7), 723–728.
5. Wang, S., Jiang, X., Han, X., Tong, J. Investigation of Chinese oil shale resources comprehensive utilization performance. *Energy*, 2012, **42**(1), 224–232.
6. Hotta, A., Parkkonen, R., Hiltunen, M., Arro, H., Loosaar J., Parve, T., Pihu, T., Prikk, A., Tiikma, T. Experience of Estonian oil shale combustion based on CFB technology at Narva Power Plants. *Oil Shale*, 2005, **22**(4S), 381–397.
7. Han, X., Jiang, X., Wang, H., Cui, Z. Study on design of Huadian oil shale-fired circulating fluidized bed boiler. *Fuel Process. Technol.*, 2006, **87**(4), 289–295.
8. Jiang, X. M., Han, X. X., Cui, Z. G. New technology for the comprehensive utilization of Chinese oil shale resources. *Energy*, 2007, **32**(5), 772–777.
9. EPD International AB. *Product-Specific Requirements (PSR) for Preparing an Environmental Product Declaration (EPD) for Electricity and District Heat Generation” (PSR 2004:2)*. PSR, Stockholm, 2011. www.environdec.com/
10. Talve, S., Riipulk, V. An inventory analysis of oil shale energy produced on a small thermal power plant. *J. Clean. Prod.*, 2001, **9**(3), 233–242.
11. Talve, S., Riipulk, V. Suggestions to improve oil shale industry water management basing on inventory analysis of Life Cycle Assessment. *Oil Shale*, 2001, **18**(1), 35–46.
12. Mangmeechai, A., Jaramillo, P., Griffin, W. M., Matthews, H. S. Life cycle consumptive water use for oil shale development and implications for water supply in the Colorado River Basin. *Int. J. Life Cycle Assess.*, 2014, **19**(3), 677–687. doi: <https://doi.org/10.1007/s11367-013-0651-8>
13. Koskela, S., Seppälä, J., Lipp, A., Hiltunen, M.-R., Pöld, E., Talve, S. Estonian electricity supply scenarios for 2020 and their environmental performance. *Energy Policy*, 2007, **35**(7), 3571–3582.
14. International Organization for Standardization. *ISO 14040:2006. Environmental management – Life cycle assessment – Principles and framework*. ISO, 2006.
15. EPD International AB. *Product Category Rules CPC 171 & 173: Electricity, Steam, and Hot and Cold Water Generation and Distribution; PCR 2007:08, Version 2.01*. PCR, Stockholm, 2011. <https://environdec.com/>
16. EPD International. *General Programme Instructions of the International EPD® System. Version 1.0*, dated 2008-02-29.